

EVALUATION KIT
AVAILABLE

MAXIM

+3.3V, 622Mbps SDH/SONET Laser Driver with Current Monitors and APC

General Description

The MAX3663 is a complete, +3.3V laser driver with automatic power-control (APC) circuitry for SDH/SONET applications up to 622Mbps. It accepts differential PECL inputs, provides bias and modulation currents, and operates over a -40°C to +85°C temperature range.

An APC feedback loop is incorporated to maintain a constant average optical power over temperature and lifetime. The wide modulation current range from 5mA to 75mA and bias current of 1mA to 80mA are easy to program, making this product ideal for use in various SDH/SONET applications. Two pins are provided to monitor the current levels in the laser: BIASMON with current proportional to laser bias current, and MODMON with current proportional to laser modulation.

The MAX3663 also provides enable control and a failure-monitor output to indicate when the APC loop is unable to maintain the average optical power. The MAX3663 is available in a compact 4mm x 4mm 24-pin thin QFN package.

Applications

622Mbps SDH/SONET Access Nodes
Laser Driver Transmitters
Section Regenerators
FTTH/FTTC Applications

Features

- ◆ +3.3V or +5.0V Single-Supply Operation
- ◆ 40mA Supply Current at +3.3V
- ◆ Programmable Bias Current from 1mA to 80mA
- ◆ Programmable Modulation Current from 5mA to 75mA
- ◆ Bias Current and Modulation Current Monitors
- ◆ 200ps Rise/Fall Time
- ◆ Automatic Average Power Control with Failure Monitor
- ◆ Complies with ANSI, ITU, and Bellcore SONET/SDH Specifications
- ◆ Enable Control

Ordering Information

PART	TEMP RANGE	PIN-PACKAGE
MAX3663ETG	-40°C to +85°C	24 Thin QFN (4mm x 4mm)
MAX3663ETG+	-40°C to +85°C	24 Thin QFN (4mm x 4mm)

+Denotes lead-free package.

Pin Configuration appears at end of data sheet.

Typical Application Circuit

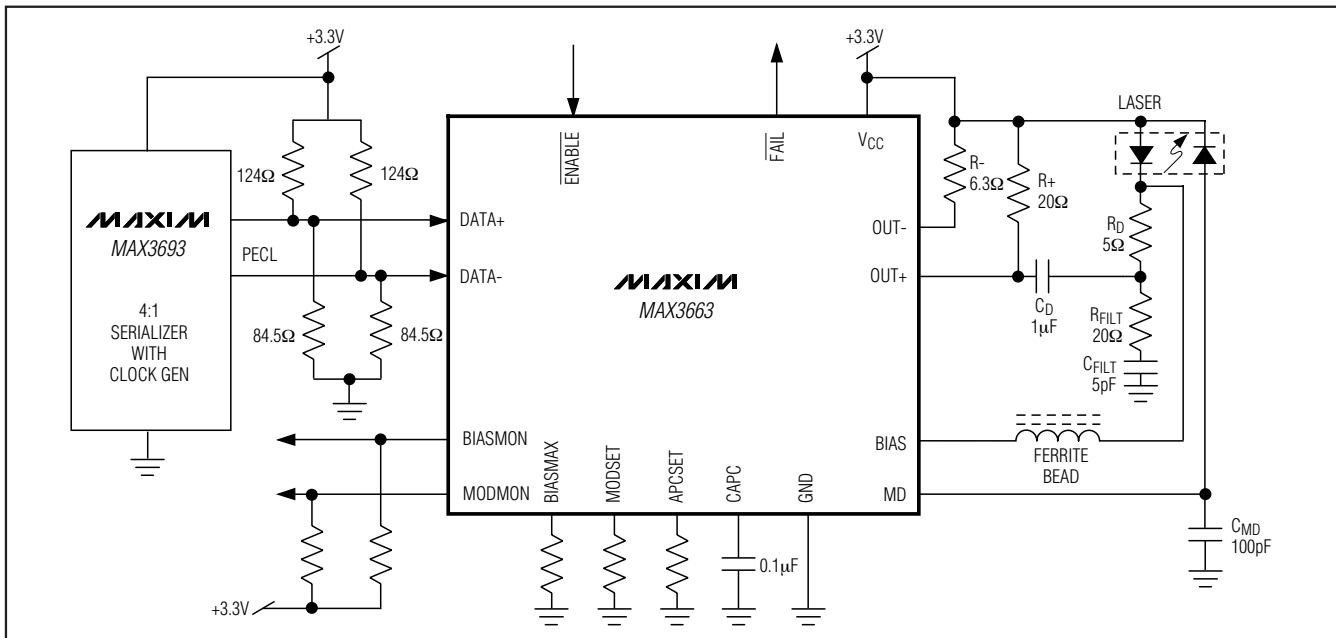

MAXIM

Maxim Integrated Products 1

For pricing, delivery, and ordering information, please contact Maxim/Dallas Direct! at 1-888-629-4642, or visit Maxim's website at www.maxim-ic.com.

MAX3663

+3.3V, 622Mbps SDH/SONET Laser Driver with Current Monitors and APC

ABSOLUTE MAXIMUM RATINGS

Supply Voltage, V_{CC} -0.5V to +7.0V
 Current into BIAS -20mA to +150mA
 Current into OUT+, OUT- -20mA to +100mA
 Current into MD -5mA to +5mA
 Voltage at DATA+, DATA-, \overline{ENABLE} ,
 FAIL, BIASMON, MODMON -0.5V to ($V_{CC} + 0.5V$)
 Voltage at OUT+, OUT- +1.5V to ($V_{CC} + 1.5V$)
 Voltage at MODSET, APCSET, BIASMAX,
 CAPC -0.5V to +3.0V

Voltage at BIAS +1.0V to ($V_{CC} + 0.5V$)
 Continuous Power Dissipation ($T_A = +85^\circ\text{C}$)
 24-Lead Thin QFN
 (derate 20.8mW/ $^\circ\text{C}$ above +85 $^\circ\text{C}$) 1354mW
 Operating Junction Temperature Range -55 $^\circ\text{C}$ to +150 $^\circ\text{C}$
 Processing Temperature (Die) +400 $^\circ\text{C}$
 Storage Temperature Range -65 $^\circ\text{C}$ to +165 $^\circ\text{C}$
 Lead Temperature (soldering, 10s) +300 $^\circ\text{C}$

Stresses beyond those listed under "Absolute Maximum Ratings" may cause permanent damage to the device. These are stress ratings only, and functional operation of the device at these or any other conditions beyond those indicated in the operational sections of the specifications is not implied. Exposure to absolute maximum rating conditions for extended periods may affect device reliability.

DC ELECTRICAL CHARACTERISTICS

($V_{CC} = +3.14V$ to +5.5V, $T_A = -40^\circ\text{C}$ to +85 $^\circ\text{C}$, unless otherwise noted. Typical values are at $V_{CC} = +3.3V$, $T_A = +25^\circ\text{C}$.)

PARAMETER	SYMBOL	CONDITIONS	MIN	TYP	MAX	UNITS	
Supply Current		(Note 1)		40	60	mA	
Bias Current Range	I_{BIAS}	$V_{BIAS} = V_{CC} - 1.6V$	1		80	mA	
Bias Off Current		$\overline{ENABLE} = \text{high}$ (Note 2)			100	μA	
Bias Current Stability		APC open loop	$I_{BIAS} = 80\text{mA}$		255	ppm/ $^\circ\text{C}$	
			$I_{BIAS} = 1\text{mA}$				815
Bias Current Absolute Accuracy		APC open loop, $3\text{mA} \leq I_{BIAS} \leq 80\text{mA}$	-15		+15	%	
Differential Input Voltage	V_{ID}	Figure 1	200		1600	mV _{P-P}	
Common-Mode Input Voltage	V_{ICM}	PECL compatible (Table 2)	$V_{CC} - 1.49$	$V_{CC} - 1.32$	$V_{CC} - V_{ID}/4$	V	
DATA+, DATA- Input Current	I_{IN}		-1		+10	μA	
Monitor Diode Current Stability		(Note 3)	$I_{MD} = 1\text{mA}$		-480	-50	+480
			$I_{MD} = 18\mu\text{A}$ (Note 4)				
Monitor Diode Current Absolute Accuracy			-15		+15	%	
DC Monitor Diode Current	I_{MD}		18		1000	μA	
BIASMON to I_{BIAS} Gain	A_{BIAS}	$I_{BIAS}/I_{BIASMON}$		38		mA/mA	
MODMON to I_{MOD} Gain	A_{MOD}	I_{MOD}/I_{MODMON}		29		mA/mA	
Monitor Diode Input Voltage (MD Pin)	V_{MD}			0.8		V	
TTL Input High Voltage	V_{IH}		2			V	
TTL Input Low Voltage	V_{IL}				0.8	V	
TTL Output High Voltage (FAIL)	V_{OH}	Sourcing 50 μA	2.4	$V_{CC} - 0.3$	V_{CC}	V	
TTL Output Low Voltage (FAIL)	V_{OL}	Sinking 100 μA	0.1		0.44	V	

+3.3V, 622Mbps SDH/SONET Laser Driver with Current Monitors and APC

MAX3663

AC ELECTRICAL CHARACTERISTICS

($V_{CC} = +3.14V$ to $+5.5V$, load as shown in Figure 2, $T_A = -40^{\circ}C$ to $+85^{\circ}C$, unless otherwise noted. Typical values are at $V_{CC} = +3.3V$, $T_A = +25^{\circ}C$.) (Note 6)

PARAMETER	SYMBOL	CONDITIONS	MIN	TYP	MAX	UNITS
Modulation Current Range	I_{MOD}	(Note 6)	5		75	mA
Modulation Off-Current		$\overline{ENABLE} = \text{high}$ (Note 2)			200	μA
Modulation Current Stability		$I_{MOD} = 75mA$	-620	-165	+620	ppm/ $^{\circ}C$
		$I_{MOD} = 5mA$ (Note 4)		205		
Modulation Current Absolute Accuracy			-15		+15	%
Output Rise/Fall Time	t_R, t_F	20% to 80%, $R_L = 10\Omega 20\Omega$ load	$I_{MOD} = 5mA$	100	200	ps
			$I_{MOD} = 75mA$	230	375	
Jitter Generation (Peak-to-Peak)		(Note 7)			100	ps
Pulse-Width Distortion (Peak-to-Peak)		(Notes 8, 9)	$I_{MOD} = 5mA$	70	155	ps
			$I_{MOD} = 75mA$	10	135	
Enable/Startup Delay		Open loop		250		ns
Maximum Consecutive Identical Digits at 622Mbps	CID		80			Bits

Note 1: Tested with $R_{MODSET} = 5.11k\Omega$ ($I_{MOD} \approx 38mA$), $R_{BIASMAX} = 4.56k\Omega$ ($I_{BIAS} \approx 52mA$), excluding I_{BIAS} and I_{MOD} .

Note 2: Both the bias and modulation currents are disabled if any of the current set pins are shorted to ground.

Note 3: Guaranteed by design and characterization. This assumes that the laser to monitor diode transfer function does not change with temperature.

Note 4: See the *Typical Operating Characteristics* for worst-case distributions.

Note 5: AC characteristics are guaranteed by design and characterization.

Note 6: Total I_{MOD} out of $OUT+$. See the *Design Procedure* section for information regarding current delivered to the laser.

Note 7: Input signal is a 622Mbps, $2^{13} - 1$ PRBS with eighty inserted 0s.

Note 8: Input signal is a 622Mbps, 11110000 pattern.

Note 9: $PWD = (\text{wider pulse} - \text{narrower pulse}) / 2$.

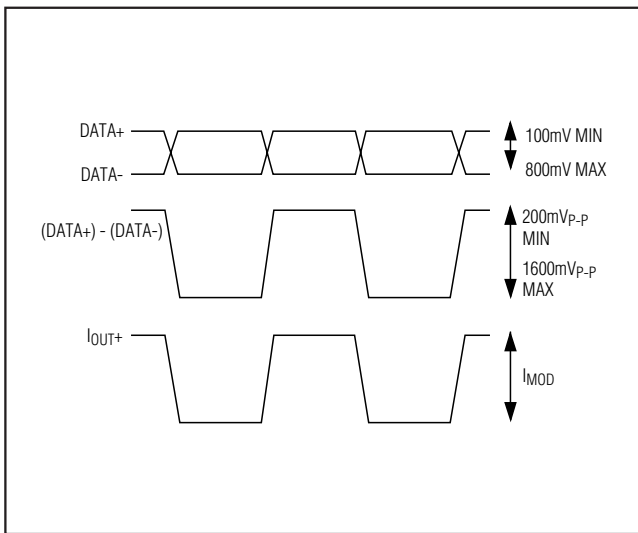

Figure 1. Required Input Signal and Output Polarity

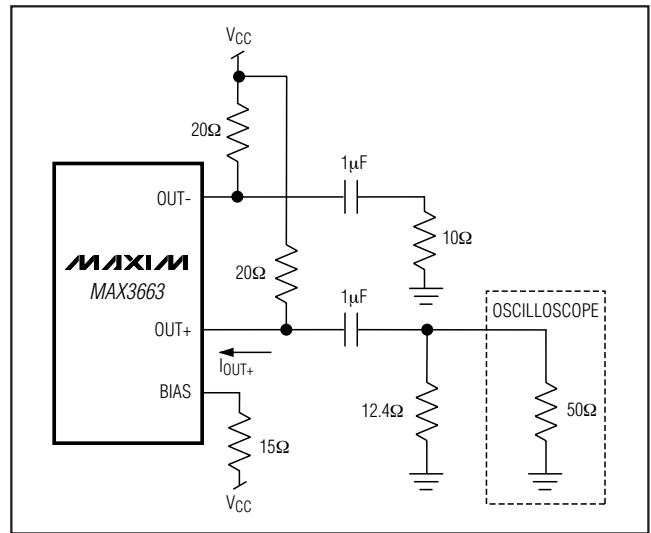

Figure 2. Output Termination for Characterization

+3.3V, 622Mbps SDH/SONET Laser Driver with Current Monitors and APC

Typical Operating Characteristics

(V_{CC} = +3.3V, T_A = +25°C, unless otherwise noted.)

EYE DIAGRAM
(622Mbps, 1300nm LASER
WITH 467MHz FILTER)

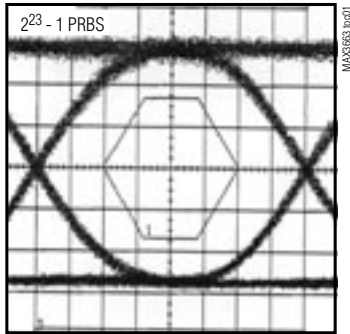

ELECTRICAL EYE DIAGRAM
(I_{MOD} = 35mA)

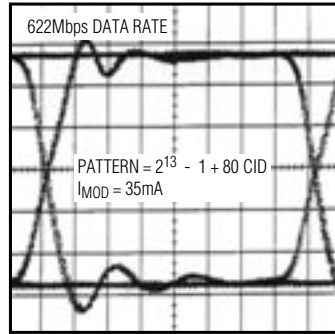

ELECTRICAL EYE DIAGRAM
(I_{MOD} = 75mA)

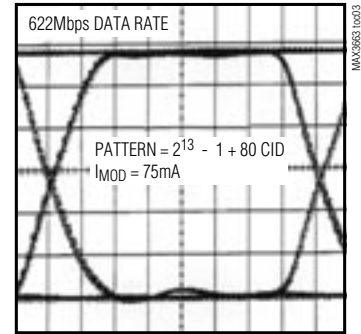

MONITOR DIODE CURRENT
vs. APC SET RESISTOR

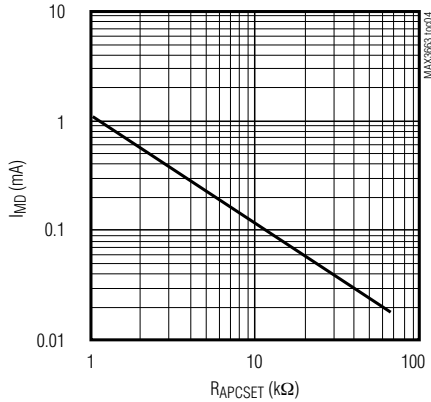

BIAS CURRENT
vs. MAXIMUM BIAS SET RESISTOR

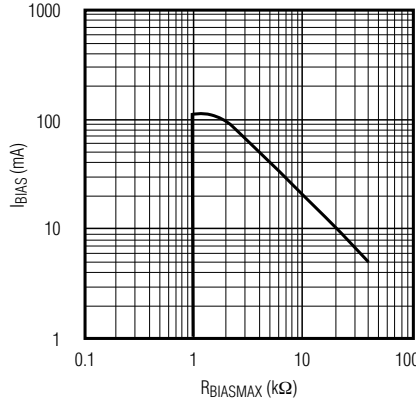

MODULATION CURRENT
vs. MODULATION SET RESISTOR

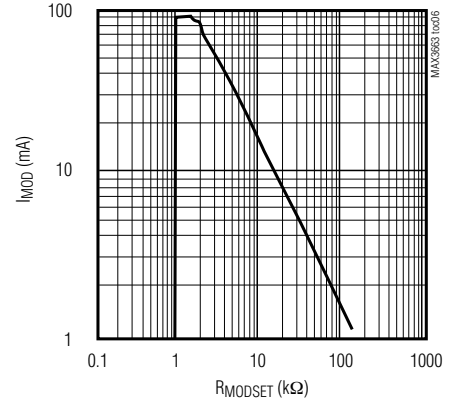

RANDOM JITTER
vs. MODULATION CURRENT

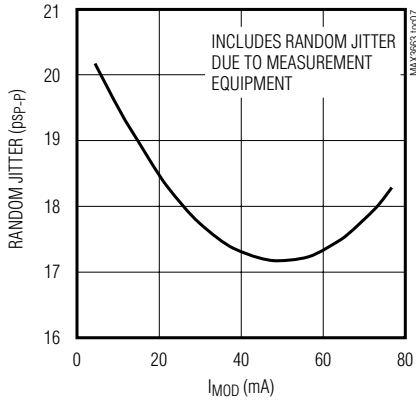

PULSE-WIDTH DISTORTION
vs. MODULATION CURRENT

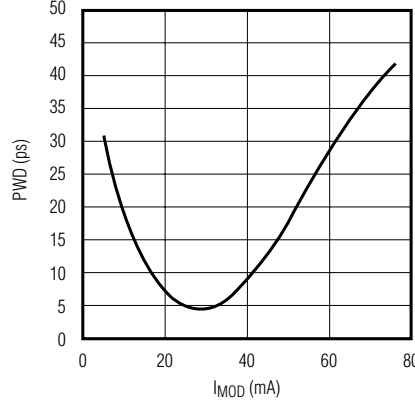

SUPPLY CURRENT
vs. TEMPERATURE

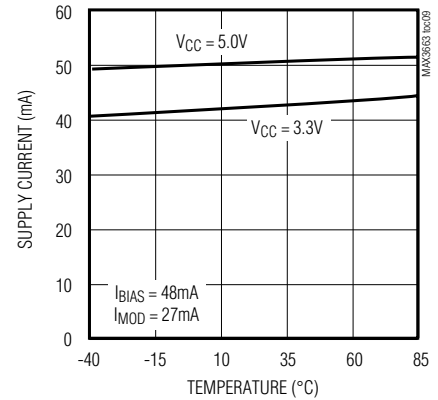

+3.3V, 622Mbps SDH/SONET Laser Driver with Current Monitors and APC

MAX3663

Typical Operating Characteristics (continued)

($V_{CC} = +3.3V$, $T_A = +25^\circ C$, unless otherwise noted.)

DISTRIBUTION OF MODULATION CURRENT STABILITY (WORST CASE)

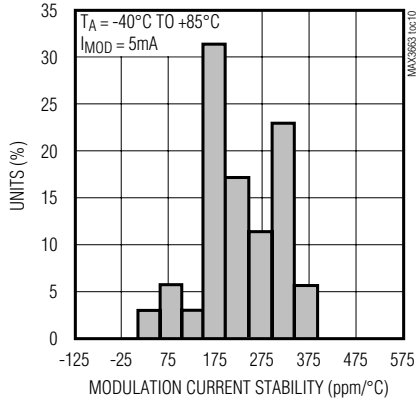

DISTRIBUTION OF MONITOR DIODE CURRENT STABILITY (WORST CASE)

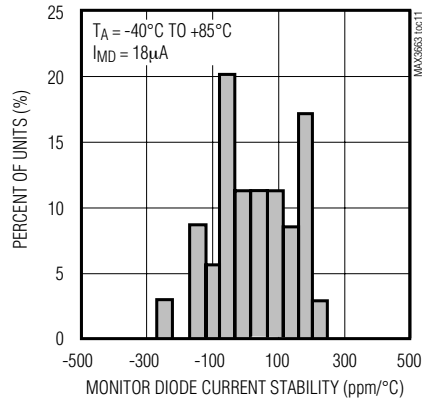

RATIO OF I_{MOD} vs. I_{MODMON}

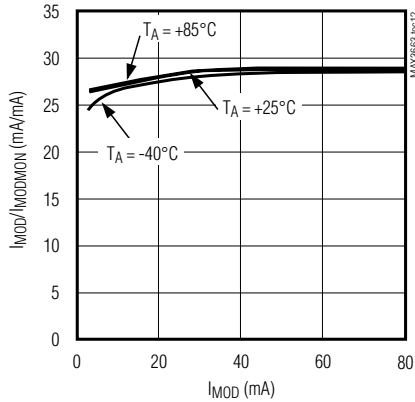

RATIO OF I_{BIAS} vs. $I_{BIASMON}$

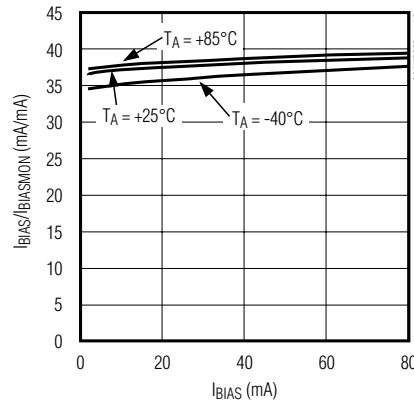

+3.3V, 622Mbps SDH/SONET Laser Driver with Current Monitors and APC

Pin Description

PIN	NAME	FUNCTION
1, 13, 16, 19	V _{CC}	Positive Supply Voltage
2	DATA+	Positive PECL Data Input
3	DATA-	Negative PECL Data Input
4, 8, 11, 17, 22	GND	Ground
5	BIASMON	Sink Current Source. Proportional to the laser bias current.
6	MODMON	Sink Current Source. Proportional to the laser modulation current.
7	$\overline{\text{ENABLE}}$	TTL/CMOS Enable Input. Low for normal operation, high to disable laser bias and modulation currents. Internally pulled low.
9	$\overline{\text{FAIL}}$	TTL Output. Indicates APC failure when low. Internally pulled high through a 6k Ω resistor.
10	N.C.	No Connection. Leave unconnected.
12	BIAS	Laser Bias Current Output. Isolate from laser with a ferrite bead.
14	OUT+	Positive Modulation Current Output. I _{MOD} flows into this pad when the input signal is high. Connect this pad to AC-coupling network.
15	OUT-	Negative Modulation Current Output. I _{MOD} flows into this pad when the input signal is low. Connect this pad to V _{CC} through a 6.3 Ω resistor.
18	MD	Monitor Photodiode Connection. Connect this pad to the monitor photodiode anode. A capacitor to ground is required to filter high-speed AC monitor photocurrent.
20	CAPC	APC Compensation Capacitor. A 0.1 μ F capacitor connected from this pad to ground controls the dominant pole of the APC feedback loop.
21	APCSET	APC Set Resistor. A resistor connected from this pad to ground sets the desired average optical power. The resulting current is equal to the desired DC monitor diode current. Connect a 100k Ω resistor from this pad to ground if APC is not used.
23	MODSET	Modulation Set Resistor. A resistor from this pad to ground sets the laser modulation current.
24	BIASMAX	Maximum Bias Set Resistor. A resistor from this pad to ground sets the maximum laser bias current. The APC function can subtract from this maximum value but cannot add to it. This resistor controls the bias-current level when the APC loop is not used.
EP	Exposed Paddle	The exposed paddle must be soldered to ground.

+3.3V, 622Mbps SDH/SONET Laser Driver with Current Monitors and APC

MAX3663

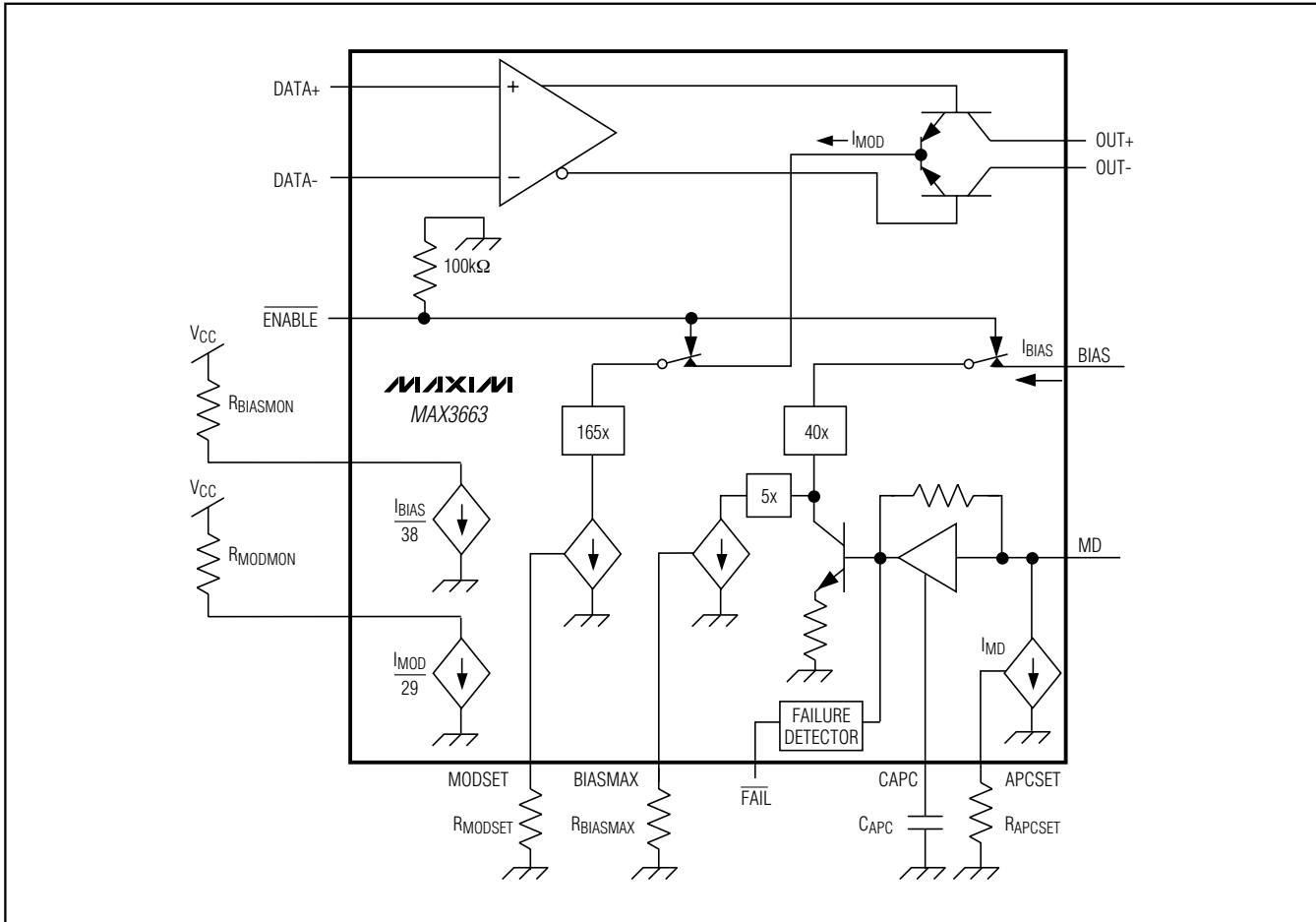

Figure 3. Functional Diagram

Detailed Description

The MAX3663 laser driver consists of three main parts: a high-speed modulation driver, a laser-biasing block with automatic power control (APC), and bias current and modulation current monitors. The circuit is optimized for low-voltage (+3.3V) operation.

The output stage is composed of a high-speed differential pair and a programmable modulation current source. Since the modulation output drives a maximum current of 75mA into the laser with a 230ps edge speed, large transient voltage spikes can be generated due to the parasitic inductance. These transients and the laser forward voltage leave insufficient headroom for the proper operation of the laser driver if the modulation output is DC-coupled to the laser diode. To solve this problem, the MAX3663's modulation output is designed to be

AC-coupled to the cathode of a laser diode. A simplified functional diagram is shown in Figure 3.

The MAX3663's modulation output is optimized for driving a $20\Omega || 10\Omega$ load; the minimum required voltage at OUT+ is 2.0V. Modulation current swings of 75mA are possible. To interface with the laser diode, a damping resistor (R_D) is required for impedance matching. An RC shunt network can be used to compensate for the laser-diode parasitic inductance, thereby improving the optical output aberrations and duty-cycle distortion.

At a 622Mbps data rate, any capacitive load at the cathode of a laser diode degrades the optical output performance. Since the BIAS output is directly connected to the laser cathode, minimize the parasitic capacitance associated with this pin by using an inductor to isolate the BIAS pin from the laser diode.

+3.3V, 622Mbps SDH/SONET Laser Driver with Current Monitors and APC

Automatic Power Control

To maintain constant average optical power, the MAX3663 incorporates an APC loop to compensate for the changes in laser threshold current over temperature and lifetime. A back-facet photodiode mounted in the laser package is used to convert the optical power into a photocurrent. The APC loop adjusts the laser bias current so the monitor current is matched to a reference current set by R_{APCSET}. The time constant of the APC loop is determined by an external capacitor (C_{APC}). To eliminate the pattern-dependent jitter associated with the APC loop-time constant and to guarantee loop stability, the recommended value for C_{APC} is 0.1μF.

When the APC loop is functioning, the maximum allowable bias current is set by an external resistor, R_{BIASMAX}. An APC failure flag (FAIL) is set low when the bias current can no longer be adjusted to achieve the desired average optical power.

APC closed-loop operation requires the user to set three currents with external resistors connected between ground and BIASMAX, MODSET, and APCSET. Detailed guidelines for these resistor settings are described in the *Design Procedure* section.

Bias and Modulation Monitors

The MAX3663 includes pins to monitor the output levels of bias and modulation current. BIASMON and MODMON sink current proportional to laser bias current and modulation current, respectively. By monitoring the current through R_{MODMON} and R_{BIASMON}, it is possible to monitor the levels of bias and modulation current in the laser (Figure 3).

Open-Loop Operation

If necessary, the MAX3663 is fully operational without APC. In this case, the laser current is directly set by two external resistors connected from ground to BIASMAX and MODSET. Connect a 100kΩ resistor from APCSET to ground and leave MD open for open-loop operation.

Table 1. Optical Power Definition

PARAMETER	SYMBOL	RELATION
Average Power	P _{AVG}	P _{AVG} = (P ₀ + P ₁) / 2
Extinction Ratio	r _e	r _e = P ₁ / P ₀
Optical Power High	P ₁	P ₁ = 2P _{AVG} × r _e / (r _e + 1)
Optical Power Low	P ₀	P ₀ = 2P _{AVG} / (r _e + 1)
Optical Amplitude	P _{P-P}	P _{P-P} = 2P _{AVG} (r _e - 1) / (r _e + 1)
Laser Slope Efficiency	η	η = P _{P-P} / I _{MODL}
Laser Modulation Current	I _{MOD}	I _{MODL} = P _{P-P} / η

Enable Control

The MAX3663 incorporates a laser driver enable function. When ENABLE is high, both the bias and modulation currents are off. The typical laser enable time is 250ns.

APC Failure Monitor

The MAX3663 provides an APC failure monitor (TTL/CMOS) to indicate an APC loop tracking failure. FAIL is set low when the APC loop can no longer adjust the bias current to maintain the desired monitor current. This output is internally pulled up to V_{CC} through a 6kΩ resistor.

Short-Circuit Protection

The MAX3663 provides short-circuit protection for the modulation, bias, and monitor current sources. If either BIASMAX, MODSET, or APCSET is shorted to ground, the bias and modulation outputs turn off.

Design Procedure

When designing a laser transmitter, the optical output is usually expressed in terms of average power and extinction ratio. Table 1 gives the relationships that are helpful in converting between the optical average power and the modulation current. These relationships are valid if the average duty cycle of the optical waveform is 50%.

Programming the Modulation Current

In addition to being a function of R_{MODSET}, the modulation current delivered to the laser (I_{MODL}) also depends on the values of the series damping resistor (R_D), the shunt compensation resistance (R_{FILT}), and the laser diode's resistance (see the *Typical Operating Circuit*).

The modulation current (assuming C_{FILT} << C_D) into the laser diode can be represented by the following:

$$I_{MODL} = I_{MOD} \left[\frac{20\Omega}{20\Omega + (R_D + r_{LASER})} \right]$$

Assuming R_D = 5Ω and r_{LASER} = 5Ω, this equation is simplified to:

$$I_{MODL} = I_{MOD}(0.67)$$

For R_D = 5.0Ω and a laser resistance of approximately 5Ω, see the Modulation Current vs. Modulation Set Resistor graph in the *Typical Operating Characteristics* and select the value of R_{MODSET} that corresponds to the required current at +25°C.

Programming the Bias Current

When using the MAX3663 in open-loop operation, the bias current is determined by the R_{BIASMAX} resistor. To select this resistor, determine the required bias current at +25°C. See the Bias Current vs. Maximum Bias Set

+3.3V, 622Mbps SDH/SONET Laser Driver with Current Monitors and APC

Resistor graph in the *Typical Operating Characteristics* and select the value of $R_{BIASMAX}$ that corresponds to the required current at +25°C.

When using the MAX3663 in closed-loop operation, the $R_{BIASMAX}$ resistor sets the maximum bias current available to the laser diode over temperature and life. The APC loop can subtract from this maximum value but cannot add to it. See the Bias Current vs. Maximum Bias Set Resistor graph in the *Typical Operating Characteristics* and select the value of $R_{BIASMAX}$ that corresponds to the end-of-life bias current at +85°C.

Programming the APC Loop

When the MAX3663's APC feature is used, program the average optical power by adjusting the APCSET resistor. To select this resistor, determine the desired monitor current to be maintained over temperature and life. See the Monitor Diode Current vs. APC Set Resistor graph in the *Typical Operating Characteristics* and select the value of R_{APCSET} that corresponds to the required current.

Interfacing with the Laser Diode

To minimize optical output aberrations due to the laser parasitic inductance, an RC shunt network can be used (see the *Typical Operating Circuit*). If R_L represents the laser diode resistance, the recommended total resistance for $R_D + R_L$ is 10Ω. Starting values for coaxial lasers are $R_{FILT} = 20\Omega$ and $C_{FILT} = 5\text{pF}$. R_{FILT} and C_{FILT} should be experimentally adjusted to optimize the output waveform. A bypass capacitor should also be placed as close to the laser anode as possible for best performance.

Pattern-Dependent Jitter (PDJ)

When transmitting NRZ data with long strings of consecutive identical digits (CIDs), LF droop can contribute to PDJ. To minimize this PDJ, two external components must be properly chosen: capacitor C_{APC} , which dominates the APC loop time constant, and AC-coupling capacitor C_D .

To filter out noise effects and guarantee loop stability, the recommended value for C_{APC} is 0.1μF. This results

in an APC loop bandwidth of 20kHz. Consequently, the PDJ associated with an APC loop time constant can be ignored.

The time constant associated with the DC-blocking capacitor on I_{MOD} effects PDJ. It is important that this time constant produce minimum droop for long consecutive bit streams.

Referring to Figure 4, the droop resulting from long time periods without transitions can be represented by the following equation:

$$(100\% - \text{DROOP}) = e^{-\frac{t}{\tau}}$$

AC-coupling of I_{MOD} results in a discharge level for τ that is equal to P_{AVG} . An overall droop of 6% relative to P_{P-P} equates to a 12% droop relative to P_{AVG} . To ensure a droop of less than 12% (6% relative to P_{P-P}), this equation can be solved for τ as follows:

$$\tau = \frac{-t}{\ln(1 - 0.12)} = 7.8t$$

If t_1 equals 80 consecutive unit intervals without a transition, the time constant associated with the DC blocking capacitor needs to be longer than:

$$\tau_{AC} \geq R_{ACCD} = 7.8 (80 \text{ bits}) (1.6\text{ns/bit}) = 1.0\mu\text{s}$$

R_{FILT} can be ignored for $C_{FILT} \ll C_D$; therefore, the estimated value of R_{AC} is:

$$R_{AC} = 20\Omega \parallel (R_D + r_{LASER})$$

Assuming $R_D = 5\Omega$, and $r_{LASER} = 5\Omega$:

$$R_{AC} = 6.7\Omega$$

with $C_D = 1\mu\text{F}$, $\tau_{AC} = 6.7\mu\text{s}$.

Input Termination Requirement

The MAX3663 data inputs are PECL compatible (Table 2). However, it is not necessary to drive the MAX3663 with a standard PECL signal. As long as the specified common-mode voltage and differential voltage swings are met, the MAX3663 will operate properly.

Table 2. PECL-Compatible Input Voltage Range

PECL-COMPATIBLE INPUTS (DATA+, DATA-)	SYMBOL	VICM = VCC - 1.0		VICM = VCC - 1.32V		VICM = VCC - 1.4		UNITS
		MIN	MAX	MIN	MAX	MIN	MAX	
Input High Voltage	VH	VCC - 0.95	VCC - 0.60	VCC - 1.27	VCC - 0.92	VCC - 1.35	VCC - 1.00	V
Input Low Voltage	VL	VCC - 1.40	VCC - 1.05	VCC - 1.72	VCC - 1.37	VCC - 1.80	VCC - 1.45	V

+3.3V, 622Mbps SDH/SONET Laser Driver with Current Monitors and APC

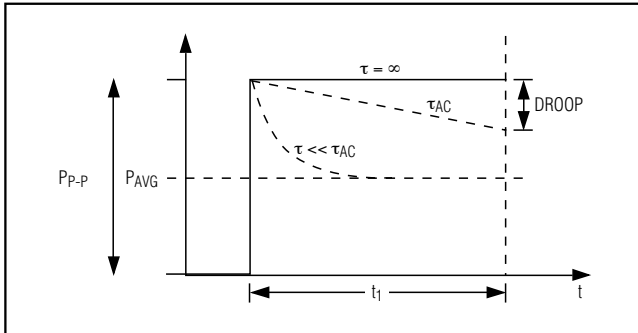

Figure 4. Droop

Calculate Power Consumption

The total power dissipation of the MAX3663 can be estimated by the following:

$$P = V_{CC} \times I_{CC} + (V_{CC} - V_f) \times I_{BIAS} + I_{MOD} (V_{CC} - 20\Omega \times I_{MOD} / 2)$$

where I_{BIAS} is the maximum bias current set by $R_{BIASMAX}$, I_{MOD} is the modulation current, and V_f is the typical laser forward voltage.

Applications Information

The following is an example of how to set up the MAX3663.

Select Laser

A communication-grade laser should be selected for 622Mbps applications. Assume the laser output average power is $P_{AVG} = 0\text{dBm}$, the minimum extinction ratio is $r_e = 6.6$ (8.2dB), the operating temperature is -40°C to $+85^\circ\text{C}$, and the laser diode has the following characteristics:

Wavelength:	$\lambda = 1.3\mu\text{m}$
Threshold Current:	$I_{TH} = 22\text{mA}$ at $+25^\circ\text{C}$
Threshold Temperature Coefficient:	$\beta_{TH} = 1.3\%/^\circ\text{C}$
Laser to Monitor Transfer:	$\rho_{MON} = 0.2\text{A/W}$
Laser Slope Efficiency:	$\eta = 0.05\text{mW/mA}$ at $+25^\circ\text{C}$

Determine R_{APCSET}

The desired monitor diode current is estimated by $I_{MD} = P_{AVG} \times \rho_{MON} = 200\mu\text{A}$. The Monitor Diode Current vs. APC Set Resistor graph in the *Typical Operating Characteristics* shows that R_{APCSET} should be $6\text{k}\Omega$.

Determine R_{MODSET}

To achieve a minimum extinction ratio (r_e) of 6.6dB over temperature and lifetime, calculate the required extinction ratio at $+25^\circ\text{C}$. Assuming $r_e = 20$, the peak-to-peak optical power $P_{P-P} = 1.81\text{mW}$, according to Table 1. The required modulation current is $1.81(\text{mW}) / 0.05(\text{mW/mA}) = 36.2\text{mA}$. The Modulation Current vs. Modulation Set Resistor graph (see *Typical Operating Characteristics*) shows that R_{MODSET} should be $5\text{k}\Omega$.

Determine $R_{BIASMAX}$

Calculate the maximum threshold current ($I_{TH(MAX)}$) at $T_A = +85^\circ\text{C}$ and end of life. Assuming $I_{TH(MAX)} = 50\text{mA}$, the maximum bias current should be:

$$I_{BIAS} = I_{TH(MAX)} + I_{MOD} / 2$$

In this example, $I_{BIAS} = 68.1\text{mA}$. The Bias Current vs. Maximum Bias Set Resistor graph in the *Typical Operating Characteristics* shows that $R_{BIASMAX}$ should be $3\text{k}\Omega$.

Determine $R_{BIASMON}$

To avoid saturating the current mirror of $BIASMON$, the voltage at this pin should not drop below $(V_{CC} - 1.6\text{V})$. The resulting condition is:

$$R_{BIASMON} \leq 1.6\text{V} \left(\frac{I_{BIAS}}{I_{BIASMAX}} \right)$$

where $I_{BIASMAX}$ is the maximum current expected for the application.

Determine R_{MODMON}

To avoid saturating the current mirror of $MODMON$, the voltage at this pin should not drop below $(V_{CC} - 1\text{V})$. The resulting condition is:

$$R_{MODMON} \leq 1\text{V} \left(\frac{I_{MOD}}{I_{MOD}} \right)$$

Modulation Currents Exceeding 50mA

To drive modulation currents greater than 50mA at 3.3V, external pullup inductors (Figure 5) should be used to DC-bias the modulation output at V_{CC} . Such a configuration isolates the laser forward voltage from the output circuitry and allows the output at $OUT+$ to swing above and below the supply voltage V_{CC} .

+3.3V, 622Mbps SDH/SONET Laser Driver with Current Monitors and APC

MAX3663

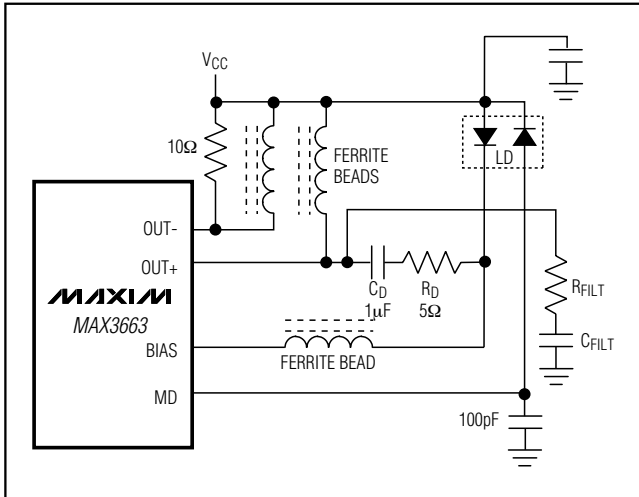

Figure 5. Output Termination for Maximum Modulation Current

At +5V power supply, the headroom voltage for the MAX3663 is significantly improved. In this case, it is possible to achieve a modulation current of more than 50mA (using resistor pullups as shown in the *Typical Operating Circuit*). The MAX3663 can also be DC-coupled to a laser diode when operating at +5V supply; the voltage at OUT+ should be $\geq 2.0V$ for proper operation.

Wire Bonding Die

For high-current density and reliable operation, the MAX3663 uses gold metalization. Make connections to the die with gold wire only, using ball-bonding techniques. Wedge bonding is not recommended. Die-pad size is 4 mils (100 μ m) square, and die thickness is 12 mils (300 μ m).

Layout Considerations

To minimize inductance, keep the connections between the MAX3663 output pins and LD as close as possible. Optimize the laser diode performance by placing a bypass capacitor as close as possible to the laser anode. Use good high-frequency layout techniques and multilayer boards with uninterrupted ground planes to minimize EMI and crosstalk.

Laser Safety and IEC 825

Using the MAX3663 laser driver alone does not ensure that a transmitter design is compliant with IEC 825. The entire transmitter circuit and component selections must be considered. Customers must determine the level of fault tolerance required by their application, recognizing that Maxim products are not designed or authorized for use as components in systems intended for surgical implant into the body, for applications intended to support or sustain life, or for any other application where the failure of a Maxim product could create a situation where personal injury or death may occur.

Pin Configuration

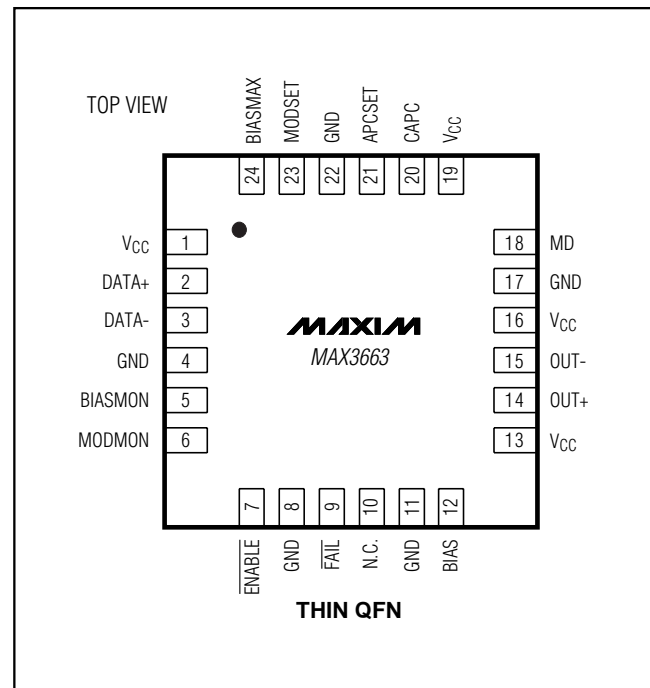

Chip Information

TRANSISTOR COUNT: 1525
SUBSTRATE CONNECTED TO GND

+3.3V, 622Mbps SDH/SONET Laser Driver with Current Monitors and APC

Package Information

(The package drawing(s) in this data sheet may not reflect the most current specifications. For the latest package outline information, go to www.maxim-ic.com/packages.)

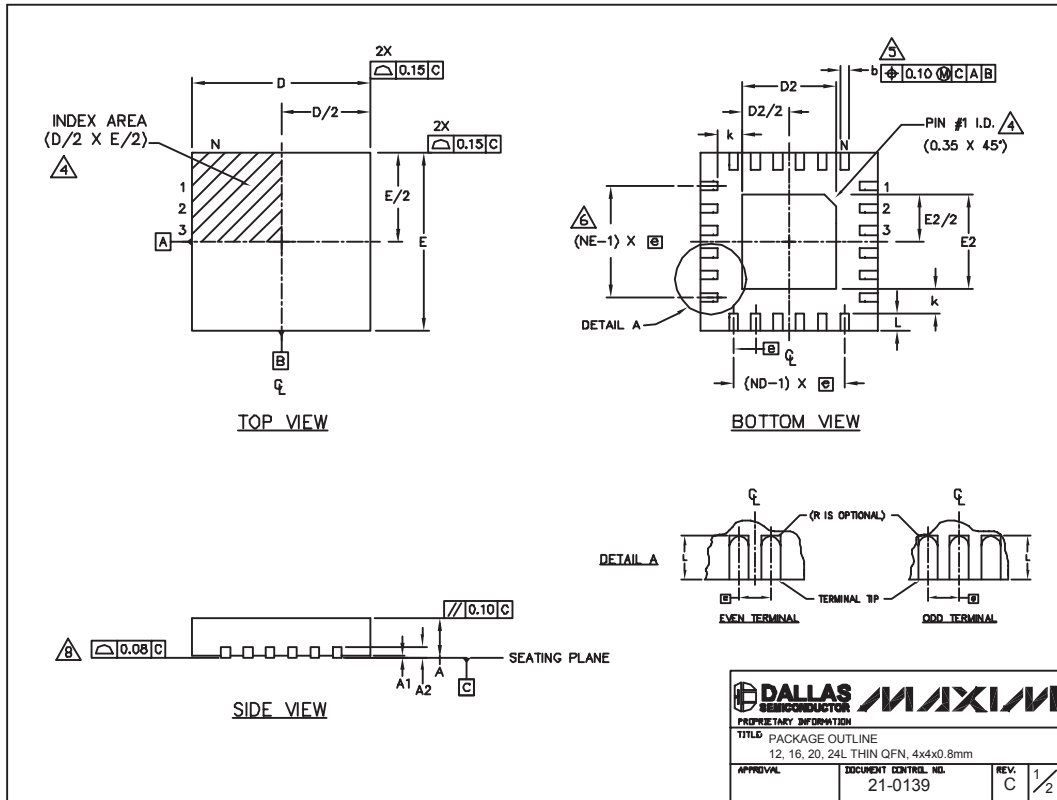

24L QFN THINLEPS

PROPRIETARY INFORMATION		
TITLE PACKAGE OUTLINE 12, 16, 20, 24L THIN QFN, 4x4x0.8mm		
APPROVAL	DOCUMENT CONTROL NO. 21-0139	REV. C 1/2

+3.3V, 622Mbps SDH/SONET Laser Driver with Current Monitors and APC

Package Information (continued)

(The package drawing(s) in this data sheet may not reflect the most current specifications. For the latest package outline information, go to www.maxim-ic.com/packages.)

MAX3663

COMMON DIMENSIONS												
PKG	12L 4x4			16L 4x4			20L 4x4			24L 4x4		
REF.	MIN.	NDM.	MAX.	MIN.	NDM.	MAX.	MIN.	NDM.	MAX.	MIN.	NDM.	MAX.
A	0.70	0.75	0.80	0.70	0.75	0.80	0.70	0.75	0.80	0.70	0.75	0.80
AI	0.0	0.02	0.05	0.0	0.02	0.05	0.0	0.02	0.05	0.0	0.02	0.05
A2	0.20 REF.			0.20 REF.			0.20 REF.			0.20 REF.		
b	0.25	0.30	0.35	0.25	0.30	0.35	0.20	0.25	0.30	0.18	0.23	0.30
D	3.90	4.00	4.10	3.90	4.00	4.10	3.90	4.00	4.10	3.90	4.00	4.10
E	3.90	4.00	4.10	3.90	4.00	4.10	3.90	4.00	4.10	3.90	4.00	4.10
e	0.80 BSC.			0.65 BSC.			0.50 BSC.			0.50 BSC.		
k	0.25	-	-	0.25	-	-	0.25	-	-	0.25	-	-
L	0.45	0.55	0.65	0.45	0.55	0.65	0.45	0.55	0.65	0.30	0.40	0.50
N	12			16			20			24		
ND	3			4			5			6		
NE	3			4			5			6		
JeDEC Ver.	WGGB			WGGC			WGGD-1			WGGD-2		

EXPOSED PAD VARIATIONS							
PKG CODES	D2			E2			DOWN BONDS ALLOWED
	MIN.	NDM.	MAX.	MIN.	NDM.	MAX.	
T1244-2	1.95	2.10	2.25	1.95	2.10	2.25	NO
T1244-3	1.95	2.10	2.25	1.95	2.10	2.25	YES
T1244-4	1.95	2.10	2.25	1.95	2.10	2.25	NO
T1644-2	1.95	2.10	2.25	1.95	2.10	2.25	NO
T1644-3	1.95	2.10	2.25	1.95	2.10	2.25	YES
T1644-4	1.95	2.10	2.25	1.95	2.10	2.25	NO
T2044-1	1.95	2.10	2.25	1.95	2.10	2.25	NO
T2044-2	1.95	2.10	2.25	1.95	2.10	2.25	YES
T2044-3	1.95	2.10	2.25	1.95	2.10	2.25	NO
T2444-1	2.45	2.60	2.63	2.45	2.60	2.63	NO
T2444-2	1.95	2.10	2.25	1.95	2.10	2.25	YES
T2444-3	2.45	2.60	2.63	2.45	2.60	2.63	YES
T2444-4	2.45	2.60	2.63	2.45	2.60	2.63	NO

NOTES:

- DIMENSIONING & TOLERANCING CONFORM TO ASME Y14.5M-1994.
- ALL DIMENSIONS ARE IN MILLIMETERS. ANGLES ARE IN DEGREES.
- N IS THE TOTAL NUMBER OF TERMINALS.

⚠ THE TERMINAL #1 IDENTIFIER AND TERMINAL NUMBERING CONVENTION SHALL CONFORM TO JEDEC 95-1 SPP-012. DETAILS OF TERMINAL #1 IDENTIFIER ARE OPTIONAL, BUT MUST BE LOCATED WITHIN THE ZONE INDICATED. THE TERMINAL #1 IDENTIFIER MAY BE EITHER A MOLD OR MARKED FEATURE.

⚠ DIMENSION b APPLIES TO METALLIZED TERMINAL AND IS MEASURED BETWEEN 0.25 mm AND 0.30 mm FROM TERMINAL TIP.

⚠ ND AND NE REFER TO THE NUMBER OF TERMINALS ON EACH D AND E SIDE RESPECTIVELY.

7. DEPOPULATION IS POSSIBLE IN A SYMMETRICAL FASHION.

⚠ COPLANARITY APPLIES TO THE EXPOSED HEAT SINK SLUG AS WELL AS THE TERMINALS.

9. DRAWING CONFORMS TO JEDEC MO220, EXCEPT FOR T2444-1, T2444-3 AND T2444-4.

DALLAS SEMICONDUCTOR		MAXIM	
PROPRIETARY INFORMATION			
TITLE PACKAGE OUTLINE 12, 16, 20, 24L THIN QFN, 4x4x0.8mm			
APPROVAL	DOCUMENT CONTROL NO. 21-0139	REV. C	2/2

Maxim makes no warranty, representation, or guarantee regarding the suitability of its products for any particular purpose, nor does Maxim assume any liability arising out of the application or use of any product or circuit and specifically disclaims any and all liability, including without limitation consequential or incidental damages. "Typical" parameters can and do vary in different applications. All operating parameters, including "typicals" must be validated for each customer application by customer's technical experts. Maxim products are not designed, intended, or authorized for use as components in systems intended for surgical implant into the body, or other applications intended to support or sustain life, or for any other application in which the failure of the Maxim product could create a situation where personal injury or death may occur.

Maxim Integrated Products, 120 San Gabriel Drive, Sunnyvale, CA 94086 408-737-7600 _____ 13